

Quick Mount PV[®]

RESPECT THE ROOF[™]

Classic Composition Mount Specifications - 5/16" - PV -

Quick Mount PV[®] is an all-in-one waterproof flashing and mount to anchor photovoltaic racking systems, solar thermal panels, air conditioning units, satellite dishes, or anything you may need to secure to a new or existing roof. It is made in the USA of all aluminum and includes stainless steel hardware. It works with all standard racks, installs seamlessly and saves labor by not needing to cut away any roofing, will out live galvanized 2 to 1, and is a better low-profile mount.



ESR-2835

Split Lock Washer SS 5/16" (Not a theft-prevention feature)

Fender Washer SS 5/16" x 1"

EPDM Rubber Washer 60 Durometer 5/16"

Sealing Washer SS 5/16"

Hanger Bolt SS 5/16" x 6"

1 1/4" Machine, 1 3/4" Spacer, 3" Lag

Mount & Flashing Aluminum

Mount 1 1/4" x 1 1/4" x 2 1/4" Beveled Block

Flashing .05" thick

For standard composition roofs:

flashing is 12" x 12"

mount is attached 3" off center

(2) Hex Nuts SS 5/16"

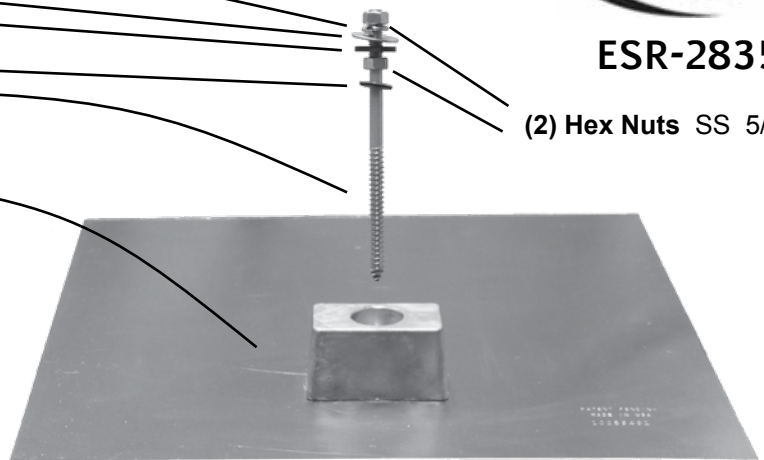

Lag pull-out (withdrawal) capacities (lbs) in typical lumber:

	Specific gravity	Lag Bolt Specifications	
		5/16" shaft per 3" thread depth	5/16" shaft per 1" thread depth
Douglas Fir, Larch	.50	798	266
Douglas Fir, South	.46	705	235
Engelmann Spruce, Lodgepole Pine (MSR 1650 f & higher)	.46	705	235
Hem, Fir	.43	636	212
Hem, Fir. (North)	.46	705	235
Southern Pine	.55	921	307
Spruce, Pine, Fir	.42	615	205
Spruce, Pine, Fir (E of 2 million psi and higher grades of MSR and MEL)	.50	798	266

Sources: Uniform Building Code; American Wood Council

Notes:

1) Thread must be embedded in a rafter or other structural roof member.

2) See IBC for required edge distances.

2700 Mitchell Dr., Bldg. 2, Walnut Creek, CA. 94598

Phone: (925) 687-6686 Fax: (925) 687-6689

Email: info@quickmountpv.com www.quickmountpv.com

Know Your Roof

It is a good idea to do a thorough roof evaluation prior to your project installation. At this time you should do a layout on the roof confirming everything on the drawing will fit as it is intended. Any irregularities should be noted now, so that you can deal with them simply on install day. The quality of the roofing should be determined, so that any repairs or replacement can happen before or in conjunction with the installation. On a composition roof it is important to know as much as possible about: the manufacturer, the age of roof, the type of substrate (plywood or oriented strand board [OSB]), the rafter size, the spacing and span, the age of roof structure, who roofed it, who built it, etc.

Photos should be taken of all of the roof variables and associated with the job file for any future reference either short term or long. Typically the building owner can look in a file and find the composition manufacturer. If not, take a piece to the roofing yard, they can usually recognize the maker and the rough vintage. It is then easy to obtain the written manufacturer's installation instructions for the roofing materials you are dealing with. The manufacturer's instructions will spell out exactly what does and does not void the warranty of their roofing product. Most have a clause about roof temperature. This is commonly missed, but can easily be noted if you read the instructions. Officially, the roofing manufacturer's instructions supersede our instructions, as our product is weaving into theirs. It is also important to have their instructions in the job file, for any future reference. If the manufacturer cannot be found, there is obviously no warranty in place.

On a roof that has a material and labor warranty in place (new roof), it is recommended to at least consult the roofer of record. Often the roofing contractor will void the labor portion of their warranty if another trade modifies their work. Give the roofing contractor the option of handling the roofing modifications, or at least give them the opportunity to inspect and approve the modifications you make. There will be fees to this roofer, but if it maintains the labor warranty it should be good money spent.

Product Selection

The Composition Mount is intended to fit within most composition and wood shingle roof systems, but not all. Specifically it is sized to fit within a standard 5" to 5 1/2" row or course. To confirm that the Comp Mount will match your roof, measure the course exposure of your roof. The "exposed" surface course height should measure no more than 5 3/4". If it turns out the roof tiles are a non-standard size greater than 5 3/4", the alternative method is to use a Quick Mount Shake Mount instead. In this case, follow the directions for the Quick Mount Shake Mount. (See Composition Mount Instructional Video at quickmountpv.com/tech.php, then Shake Composition Video:

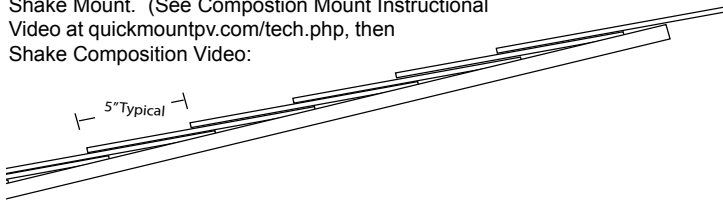

High Definition Comp - Presidential

Irregular surface - If the penetration lands in a low between two highs, it is best to shim the low under the flashing with extra asphalt to level out the surface.

Irregular tooth pattern - If the shingles have a tooth pattern wherein the bottom edge jogs up and down to give it a higher profile look, it is important to understand that the excess shingle that hangs lower than the rest of the shingle is for looks only. The 5" rule starts at the top of the tooth. If a tooth interferes with the mount block, cut the tooth off.

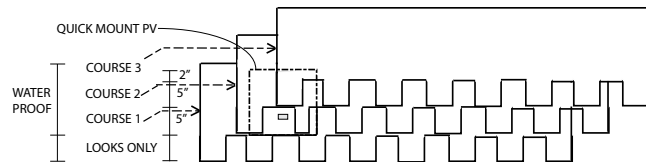

How Many Mounts Per Module?

There are two questions that must be asked when adding anything to a roof.

1. Can the roof / building / foundation handle the additional load?
2. What is to keep the new load from blowing away?

It is assumed that a licensed solar installer can answer these questions. If he / she can't, he / she will need to find somebody that can. A licensed engineer is the easiest solution. Some of the racking manufacturers have guides to calculating a code compliant install as well. Many variables must be considered and determined to complete the calculation. The spacing between mounts has the variables of: strength of rail, distance between parallel rails, cantilever of modules over rails, pull out strength of mount, slope of roof, height of roof, wind zone, roof type, structural integrity of roof framing, etc. The only values in the variables above that we can provide is pull out strength and shear of mount. We provide structural test reports on all of our mounts as needed. You will need to gather the rest of the applicable information and do the calculations for your specific project.

Further Resources

In the process of all the research we have done, we came up with what we call the "Wheel of Accountability". It is a graphical look at the many official entities that govern how waterproofing should be done. At our web site you can click on any wedge of the wheel and get the code snippets that pertain to that entity's focus on roof penetrations.

Please don't hesitate to use it to your advantage. And of course if you have any feed back pro or con, let us have it. Take photos of your jobs using Quick Mount Products and submit them to us at info@quickmountpv.com, we'll put them up in our web gallery. Put Photo Gallery in the Subject line.

Product Includes

Each box includes all necessary mounting hardware, mounts with flashing, and written instructions.

Alternative Attachment Methods

The Composition Mount is intended to be attached into a lumber rafter. Mounts are usually laid out based on the location of the rafters. In some cases it is desired to place a mount where there is no rafter. In this case it is possible to place a block between rafters, then lag into the block. In the case of metal rafters, lumber blocking the rafters is a solution, but should be done per the building's engineer of record.

Shared Rail & 5" Rule

On a shared rail system, where the mounts must be in an exact spot, it is important to make sure the unit is flashed properly. Normally the vertical placement is guided by the exposed front edge of the shingle. If (on a 5" exposure comp) the flashing is flush with this, then you have 5" of flashing over course 1, 5" of flashing under course 2, and 2" of flashing under courses 2 and 3. This is important because if there is a vertical joint in course 2 the water cannot find its way under the flashing because it extends under course 3. When the flashing must be shifted to catch a shared rail, it is advised to shift the mount up the roof only, leaving less flashing over course 1, and more flashing under course 3. If it is necessary to shift downward, it is advised to move down a whole course and then shift up accordingly.

Sealants

It is important to put a compatible sealant into any and all holes drilled into a roof. Most roofing manufactures list a suggested, approved sealant in their specifications. In the freeze-thaw zones, it is important to follow the manufacturers' rules for freeze-thaw conditions. Use the properly rated sealant for each specific application and condition. Some that may be more appropriate for asphalt/composition roofs include Geocell 2300 and ChemLink M-1 but be sure to do your own research to confirm a compatible and appropriate sealant with the materials you are working with.

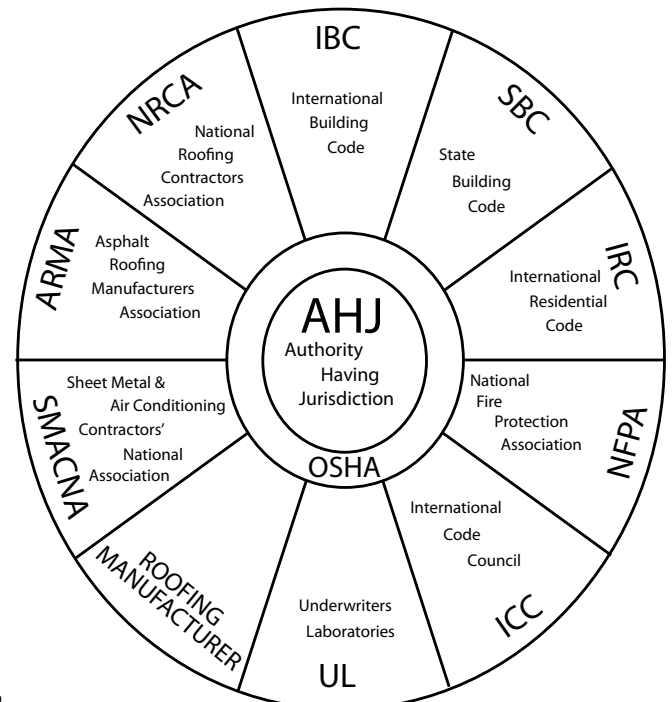

Racking of Choice
Not Included

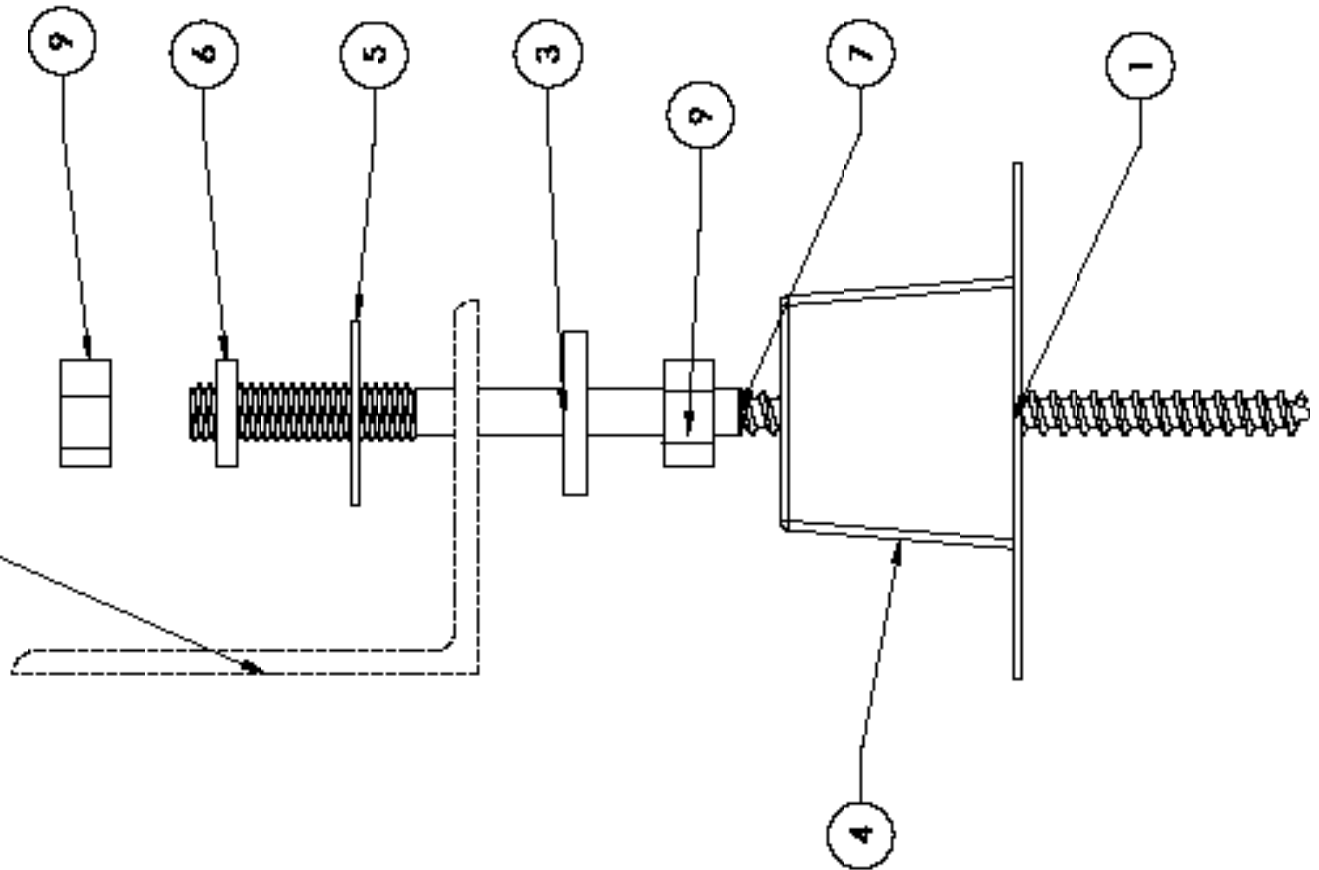
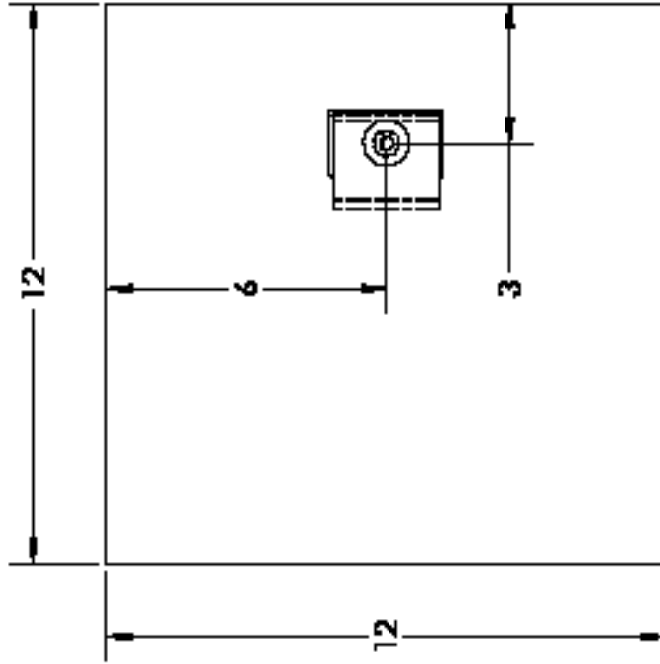

ITEM NO.	DESCRIPTION	QTY.
1	Sheet .080x12x12 Aluminum	1
2	Fastener .499x.750 H1976	1
3	EPDM Washer .125" Thick x .875" OD	1
4	QMSC Base Block for Standard Mounts	1
5	Fender Washer 5/16" x 1" SS	1
6	Split-Lock Washer 5/16"	1
7	Hanger Bolt 5/16" x 6" SS	1
8	Sealing Washer 5/16" x 3/4"	1
9	Hex Nut 5/16-18 SS	2

THIS DOCUMENT IS UNCLASSIFIED EXCEPT WHERE SHOWN OTHERWISE. ANY INFORMATION IN THIS DOCUMENT IS UNCLASSIFIED EXCEPT WHERE SHOWN OTHERWISE.

Quick Mount PV[®]

CLASSIC COMPOSITION MOUNTING INSTRUCTIONS - 5/16" - PV -

Installation Tools Required: Tape Measure, Roofing Bar, Chalk Line, Stud Finder, Caulking Gun, 1 Tube of Appropriate Sealant, Drill with 7/32" long bit, Drill or Impact Gun with 1/2" Deep Socket.



1 Locate, choose, and mark centers of rafters to be mounted. Select each row course of roofing for Mount placement of Quick Mounts.



2 Lift Composition roof shingle with Roofing Bar, just above placement of Quick Mount.



3 Slide Mount into desired position. Remove any nails that conflict with getting Mount flush with front edge of shingle course. Mark center for drilling.



4 Using drill with 7/32" long bit, drill pilot hole into roof and rafter, taking care to drill square to the roof. Do not use Mount as a drill guide.



5 Clean off any saw dust, and fill hole with Sealant.



6 Slide Mount back into position. Prepare Hanger Bolt with 1 Hex Nut and 1 Sealing Washer, insert through Block into hole and drive Hanger Bolt into rafter, tightening to 13 foot Pounds.



7 Insert EPDM Rubber Washer over Hanger Bolt into Block.



8 Using the Rack Kit Hardware, secure the rack of your choice (see 9*). Tighten to 16 foot pounds.

9 * You are now ready for the rack of your choice. Follow all the directions of the rack manufacturer as well as the module manufacturer.

All roofing manufacturers' written instructions must also be followed by anyone modifying a roof system. Please consult the roof manufacturers' specs and instructions prior to touching the roof.