



May 9, 2011

Mr. Stewart Wentworth
QUICK MOUNT PV
936 Detroit Avenue, Suite D
Concord, CA 94518-2539

Project Number 111204C

Subject: Low Slope Mount QMLS-12 Hardware Load Testing

Dear Mr. Wentworth:

As requested, Applied Materials & Engineering, Inc. (AME) has completed load-testing the QMLS-12 hardware. The purpose of our testing was to evaluate the shear load capacity of the QMLS-12 hardware attached to a commercially available 2"x4" Douglas Fir rafter.

SAMPLE DESCRIPTION

Six (6) mockup samples were delivered to our laboratory on April 20, 2011. Mockup configuration consisted of three 16" long rafters at 7"o.c., screwed to 1/2" Structural 1 plywood. The 12" (finished height) Quick Mount Standoff (QMSO) hardware is attached through the plywood into the rafter with two 5/16"x3" lag bolts torqued to 15ft-lbs. Product hardware details are provided in Appendix B.

TEST PROCEDURES & RESULTS

1. Shear Strength Parallel to Rafter

Three samples were tested for shear strength on May 5, 2011 using a United Universal testing machine. Samples were rigidly attached to the testing machine and a shear load was applied to the 5/16"x1" machine bolt connected to the aluminum standoff. The samples were loaded parallel to rafter at a constant rate of axial deformation of 0.01 in./min. without shock until failure occurred. Based on the above testing, the average ultimate shear load, parallel to rafter, of the QMLS-12 hardware in Douglas Fir was determined to be 519 lbf.

The specific gravity and moisture content of the rafter was tested in accordance with ASTM D2395, Method A (oven-dry). The average specific gravity and moisture content was determined to be 0.477 and 11.5%, respectively. Detailed results are provided in Table I. Test setup and mode of failure are provided in Appendix A.

Mr. Stuart Wentworth
QUICK MOUNT PV
Low Slope Mount QMLS-12 Load Testing
May 9, 2011

Project Number 111204C

2. Shear Strength Perpendicular to Rafter

Three samples were tested for shear strength on May 5, 2011 using a United Universal testing machine. Samples were rigidly attached to the testing machine and a shear load was applied to the 5/16"x1" machine bolt connected to the aluminum standoff. The samples were loaded perpendicular to rafter at a constant rate of axial deformation of 0.01 in./min. without shock until failure occurred. Based on the above testing, the average ultimate shear load, perpendicular to rafter, of the QMLS-12 hardware in Douglas Fir was determined to be 377 lbf.

The specific gravity and moisture content of the rafter was tested in accordance with ASTM D2395, Method A (oven-dry). The average specific gravity and moisture content was determined to be 0.457 and 11.4%, respectively. Detailed results are provided in Table II. Test setup and mode of failure are provided in Appendix A.

If you have any questions regarding the above, please do not hesitate to call the undersigned.

Respectfully Submitted,

APPLIED MATERIALS & ENGINEERING, INC.

Reviewed By:



Mohammed Faiyaz
Laboratory Manager



Armen Tajirian, Ph.D., P.E.
Principal

TABLE I
LOW SLOPE MOUNT QMLS-12
12" FINISHED HEIGHT
SHEAR LOAD PARALLEL TO RAFTER TEST RESULTS
PROJECT NUMBER 111204C

SAMPLE ID	ULTIMATE SHEAR LOAD PARALLEL TO RAFTER (LBF)	RAFTER MOISTURE CONTENT (%)	RAFTER SPECIFIC GRAVITY	FAILURE MODE¹.
12PARA-1	553	11.3	0.472	AL Base Collar Cracked
12PARA-2	484	11.8	0.479	AL Base Collar Cracked
12PARA-3	520	11.4	0.80	AL Base Collar Cracked
AVERAGE	519	11.5	0.477	..

¹. Upper bolt.

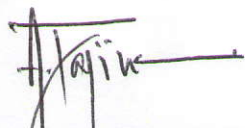
TABLE II

LOW SLOPE MOUNT QMLS-12
12" FINISHED HEIGHT

SHEAR LOAD PERPENDICULAR TO RAFTER TEST RESULTS

PROJECT NUMBER 111204C

SAMPLE ID	ULTIMATE SHEAR LOAD PERPENDICULAR TO RAFTER (LBF)	RAFTER MOISTURE CONTENT (%)	RAFTER SPECIFIC GRAVITY	FAILURE MODE
12PERP-1	344	11.3	0.471	Plywood Buckled/Bent Machine Bolt
12PERP-2	330	11.6	0.452	Plywood Buckled/Bent Machine Bolt
12PERP-3	456	11.3	0.477	Plywood Buckled/Bent Machine Bolt
AVERAGE	377	11.4	0.457	..

APPENDIX A

LOW SLOPE MOUNT QMLS-12
12" FINISHED HEIGHT

SHEAR TEST SETUP

PROJECT NUMBER 111204C

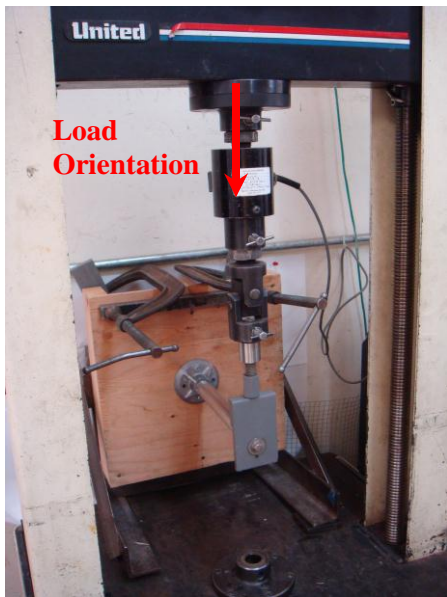

Figure 1a. Shear Parallel to Rafter

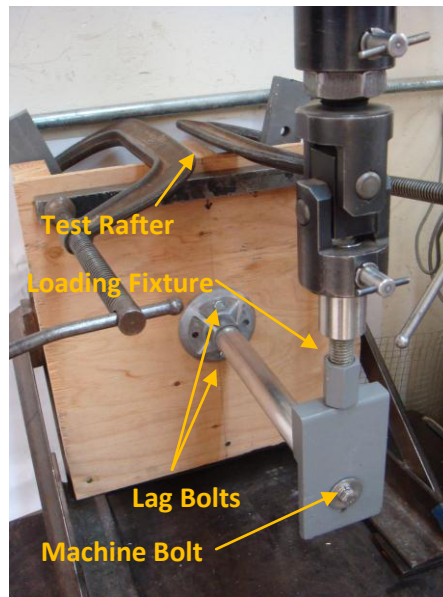

Figure 1b. Shear Test Close-up



Figure 2a. Shear Perpendicular to Rafter

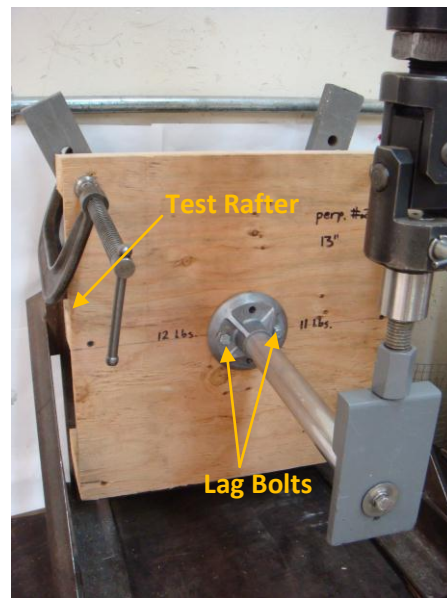

Figure 2b. Shear Test Close-up

LOW SLOPE MOUNT QMLS-12
12" FINISHED HEIGHT

FAILURE MODES

PROJECT NUMBER 111204C



Figure 3. Cracked Aluminum Base Collar
Shear Parallel to Rafter



Figure 4. Buckled Plywood
Shear Perpendicular to Rafter

APPENDIX B

LOW SLOPE MOUNT QMLS-12
12" FINISHED HEIGHT

HARWARE SPECIFICATION

PROJECT NUMBER 111204C

Quick Mount PV[®]

Your Solution in Mounting Products
 Solar • H₂O • Conduit • HVAC • Custom

Low Slope Mount Specifications

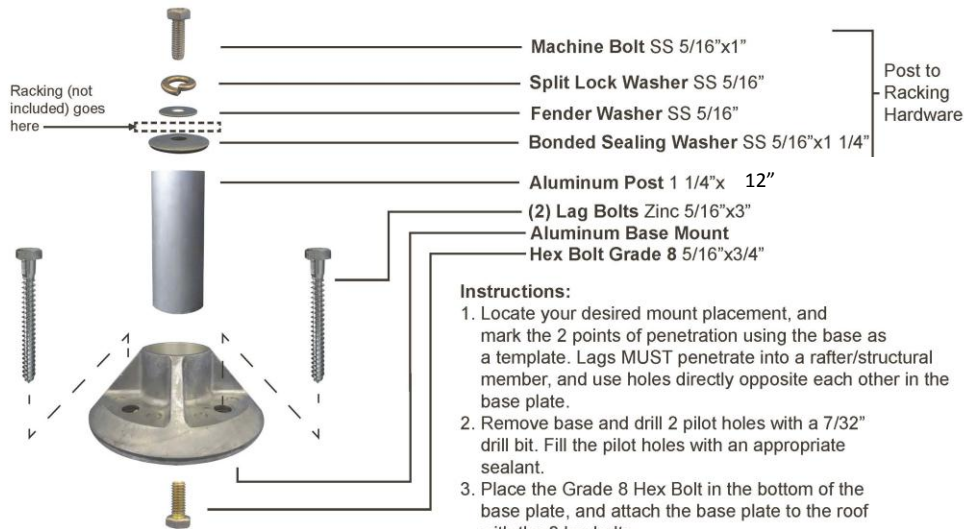

Instructions:

1. Locate your desired mount placement, and mark the 2 points of penetration using the base as a template. Lags MUST penetrate into a rafter/structural member, and use holes directly opposite each other in the base plate.
2. Remove base and drill 2 pilot holes with a 7/32" drill bit. Fill the pilot holes with an appropriate sealant.
3. Place the Grade 8 Hex Bolt in the bottom of the base plate, and attach the base plate to the roof with the 2 lag bolts.
4. Screw the post onto the Grade 8 Hex bolt in the base plate. attach the post-to-racking hardware to the top of the post for ease of location.
5. You are now ready to flash the mounts and attach racking to them.

IMPORTANT-PLEASE READ:

This product DOES NOT include flashing, and therefore is not waterproof by itself. As the installer, it is your responsibility to make sure all roof penetrations are flashed properly!

Lag pull-out (withdrawal) capacities (lbs) in typical lumber:

Lag Bolt Specifications

	Specific Gravity	2/ea 5/16" shaft per 2.5" thread depth	5/16" shaft per 1" thread depth
Douglas Fir, Larch	.50	1330	266
Douglas Fir, South	.46	1175	235
Engelmann Spruce, Lodgepole Pine (MSR 1550 f & higher)	.46	1175	235
Hem, Fir	.43	1060	212
Hem, Fir, (North)	.46	1175	235
Southern Pine	.55	1535	307
Spruce, Pine, Fir	.42	1025	205
Spruce, Pine, Fir (E of 2 million psi and higher grades of MSR and MEL)	.50	1330	266

Sources: Uniform Building Code; American Wood Council
 Notes: 1) Thread must be embedded in a rafter or other structural roof member.
 2) Pull-out values incorporate a 1.6 safety factor recommended by the American Wood Council.
 3) See IBC for required edge distances.

936 Detroit Ave Suite D, Concord, CA. 94518
 Phone: (925) 687-6686 Fax: (925) 687-6689
 Email: info@quickmountpv.com www.quickmountpv.com